

**STONY BROOK UNIVERSITY**  
**DEPARTMENT OF PHYSICS AND ASTRONOMY**

**Part II.**

**Tuesday, January 21, 2003**

**Comprehensive Examination in “Experiment” and “Breadth”**

**General instructions:** Twelve problems are given. You should do any four, subject to the constraint that you should answer **no more than three** from “experiment” and **no more than three** from “breadth” (that is, not all four problems can be chosen from the same category). Each problem should take about  $\frac{3}{4}$  hour and is worth twenty points. If a problem has subparts, each of these will be equally weighted, unless indicated otherwise, with the sum totaling twenty points. Use one examination book per problem and label it carefully with your name, the name of the problem’s author, and the date. You may not use any materials other than this examination paper and the exam books supplied, a calculator, your one page help sheet, and, with the proctor’s approval, a foreign language dictionary. None of these materials may be shared between students.

**“Experiment”**

Experiment I. (Gurvitch)

Describe various aspects of transistor physics and applications, being guided by the following questions:

- a) (4 points) Explain how a  $p-n$  junction works. Describe the Bipolar Junction Transistor (BJT) basic structure (provide a sketch) and explain how it works (you can use some Solid State Physics here)
- b) (4 points) Describe the Field Effect Transistor (FET) basic structure (provide a sketch) and explain how it works (you can use some Solid State Physics here)
- c) (4 points) Discuss various transistor gains (current, voltage, power). Where does the energy for the power gain come from?
- d) Discuss the following basic electronic applications of a transistor (explain how each application is achieved in a circuit; you can use some simple electronics circuit diagrams showing the transistor and other elements required for a given application; you can use some electronics “golden rules” here)
  - (a) (2 points) Transistor as a switch
  - (b) (2 points) Transistor as a signal amplifier (show the circuit configuration and explain how the transistor can amplify voltage)
  - (c) (2 points) Transistor as a “follower” (explain the purpose of a follower and show how it does what it does)
  - (d) (2 points) Transistor as a current source (explain why it keeps current constant despite changing load)

Experiment II. (Orozco)

The output of a Michelson interferometer operating at wavelength  $\lambda$  as a function of phase  $\delta$  is:

$$I_{out} = I_0 \left( A + B \cos^2 \frac{\delta}{2} \right) \quad (1)$$

Where the phase  $\delta$  accumulated in a displacement  $\Delta L$  of one of the mirrors is:

$$\delta = 2\pi \frac{2\Delta L}{\lambda} \quad (2)$$

The fringe visibility  $V$  in the output of the interferometer gives a quantitative indication of the quality of the interference.

$$V = \frac{I_{max} - I_{min}}{I_{max} + I_{min}} \quad (3)$$

- a) (3 points) Find the values of the ratio  $A/B$  in equation 1 to reach fringe visibilities  $V = 0.5$  and  $1.0$ .
- b) (3 points) Plot  $I_{out}$  as a function of phase  $\delta$  for  $V = 0.5$ , and  $V = 1$ . Label your axis carefully.
- c) (7 points) Consider  $V = 1$ . Find the best operating point closest to  $\delta = 0$  to maximize the output signal (around what value of  $\delta$ ) to detect a very small displacement  $\pm\epsilon$  in just one of the mirrors.
- d) (7 points) Now consider that in a real measurement you have a noise contribution from the shot noise equal to  $\sqrt{I_{out}}$ . Where should you operate the interferometer (around what value of  $\delta$ ;  $V = 1$ ), to maximize the Signal to Noise ratio.

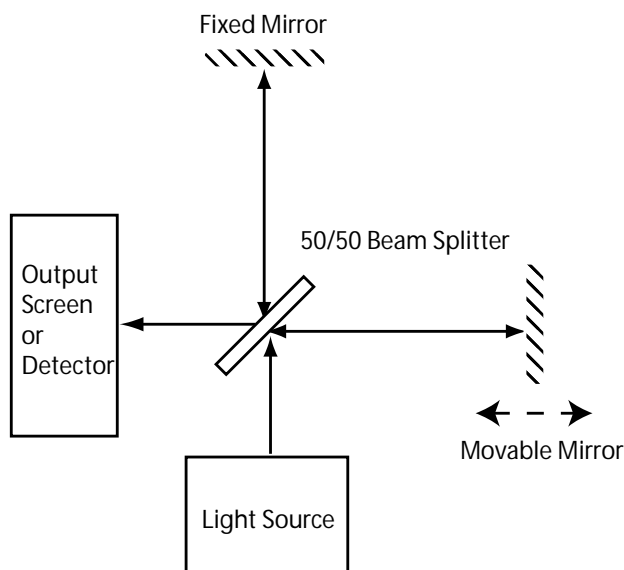

### Experiment III. (Averbeck)

The PHENIX experiment searches for signatures of a quark-gluon plasma (QGP) phase of nuclear matter in high energy collisions of heavy ions at the new Relativistic Heavy Ion Collider at Brookhaven National Laboratory. In a typical event, a few thousand particles, mainly charged and neutral pions but also kaons and baryons like the proton, are produced. Only occasionally, a  $J/\Psi$  meson is produced. Since the yield of  $J/\Psi$  mesons is expected to be sensitive to the formation of a QGP phase it is of prime importance to study  $J/\Psi$  production. The PHENIX experiment has the capability to conduct these measurements.

- a) (6 pts.) One way to reconstruct the  $J/\Psi$  is to detect and measure the decay  $J/\Psi \rightarrow e^+ + e^-$ . The identification of  $e^+/e^-$  in PHENIX relies mainly on Cerenkov detectors filled with  $\text{CO}_2$  (index of refraction  $n = 1.00043$ ) as radiator. Explain briefly the signature of charged particles penetrating a Cerenkov detector. Calculate the minimum momentum for which  $e^+/e^-$  and charged pions generate a signal in the Cerenkov detector to determine the momentum range in which these particle species can be separated from each other (masses:  $m_\pi = 0.14 \text{ GeV}/c^2$ ,  $m_e = 0.51 \text{ MeV}/c^2$ ).
- b) (6 pts.) In a particular event two  $e^+$  and one  $e^-$  are measured with the following kinematics:  
particle A:  $e^+$  with  $(p_x, p_y, p_z) = (+1.000, 0.0, +1.549) \text{ GeV}/c$   
particle B:  $e^-$  with  $(p_x, p_y, p_z) = (+1.000, 0.0, -1.549) \text{ GeV}/c$   
particle C:  $e^+$  with  $(p_x, p_y, p_z) = (-1.918, 0.0, +0.500) \text{ GeV}/c$   
Which pair can possibly come from a  $J/\Psi$  decay ( $m_e = 0.51 \text{ MeV}/c^2$ ,  $m_{J/\Psi} = 3.1 \text{ GeV}/c^2$ )? Calculate  $(E, p_x, p_y, p_z)$  for the primary  $J/\Psi$ .
- c) (6 pts.) Not all  $J/\Psi$  mesons are produced directly. A small fraction originates from decays of B mesons, e.g.  $B^0 \rightarrow J/\Psi + \text{anything}$  (mass  $m_{B^0} = 5.3 \text{ GeV}/c^2$ ). Calculate the decay lengths of a  $J/\Psi$  and a  $B^0$  meson with momenta of  $2 \text{ GeV}/c$  each (lifetimes:  $\tau_{J/\Psi} = 7.6 \times 10^{-21} \text{ s}$ ,  $\tau_{B^0} = 1.5 \times 10^{-12} \text{ s}$ ).
- d) (2 pts.) Based on your result explain briefly how you would separate direct from secondary  $J/\Psi$  mesons. What detector technology would you suggest to use in order to achieve the required position resolution?

Experiment IV. (Hobbs)

- a) (4 pts.) What are the dominant production Feynman diagrams for the processes  $p\bar{p} \rightarrow W^\pm$  and  $p\bar{p} \rightarrow Z^0$
- b) (5 pts.) Estimate the minimum beam energy necessary to produce  $W^\pm$  and  $Z^0$  in a  $p\bar{p}$  collider (assume  $M_Z \sim M_W \sim 100 \text{ GeV}/c^2$ ).
- c) (4 pts.) Explain the difference for  $W^\pm$  and  $Z^0$  production between a  $pp$  and  $p\bar{p}$  collider. What does this imply for the minimum beam energy necessary in a  $pp$  machine. Use that the average momentum fraction of sea quarks is  $x_s \sim 0.04$ .
- d) (7 pts.) Give a quantitative estimate for the ratio:

$$\frac{\sigma(p\bar{p} \rightarrow W^\pm)}{\sigma(p\bar{p} \rightarrow Z^0)} \quad (1)$$

Recall that the coupling is proportional to  $g_W(1 - \gamma_5)/\sqrt{2}$  and  $g_Z(c_V - c_A\gamma_5)$  for  $W^\pm$  and  $Z^0$ , respectively. The coefficients  $c_V$  and  $c_A$  are given by  $c_A = I_3/2$  and  $c_V = I_3/2 - 2q \sin^2(\theta_W)$ .

Experiment V. (Peterson)

Consider the Sun. It generates energy by converting Hydrogen to Helium. In the process about 0.7% of the mass of each Hydrogen atom is lost.

- a) (8 points) Write down the chain of reactions primarily responsible for the Sun's energy. Make sure the reactions you write conserve all required quantities.
- b) (4 points) If the Sun's luminosity is  $3.8 \times 10^{26} \text{ W}$  what is the corresponding rate of mass loss (in Solar masses per year,  $1M_\odot = 2.0 \times 10^{30} \text{ kg}$ )? Will the Sun lose a significant amount of its mass during its main sequence lifetime? About how much?
- c) (4 points) If the Solar wind has a density of about  $7 \times 10^6$  protons  $\text{m}^{-3}$  and a velocity of  $500 \text{ km s}^{-1}$ , what is the mass loss rate (in Solar masses per year,  $m_H = 1.67 \times 10^{-27} \text{ kg}$ ,  $1 \text{ AU} = 1.496 \times 10^8 \text{ km}$ )?
- d) (4 points) What is the neutrino flux ( $\text{m}^{-2} \text{ s}^{-1}$ ) at 1AU?

Experiment VI. (Lanzetta)

Cepheid variable stars are variable stars that pulsate in brightness in a regular fashion according to a period-luminosity relation.

- a) (5 points) Using the period-luminosity relation reproduced below, estimate the peak absolute magnitude of a Type I Cepheid variable star of pulsation period 30 days. (Recall that the absolute magnitude of the Sun is  $M = 5$ .)
- b) (5 points) Write down the Hubble relation between redshift  $z$  and distance  $d$  that applies in the local universe (i.e. for  $z \ll 1$ ) in terms of the Hubble constant  $H_0$  and the speed of light  $c$ .
- c) (10 points) Say that a particular Type I Cepheid variable star is observed with pulsation period 30 days (negligible uncertainty), redshift  $z = 0.002$  (negligible uncertainty), and apparent magnitude  $m = 25 \pm 0.2$ . Using results of parts A and B, estimate the value and uncertainty of the Hubble constant.

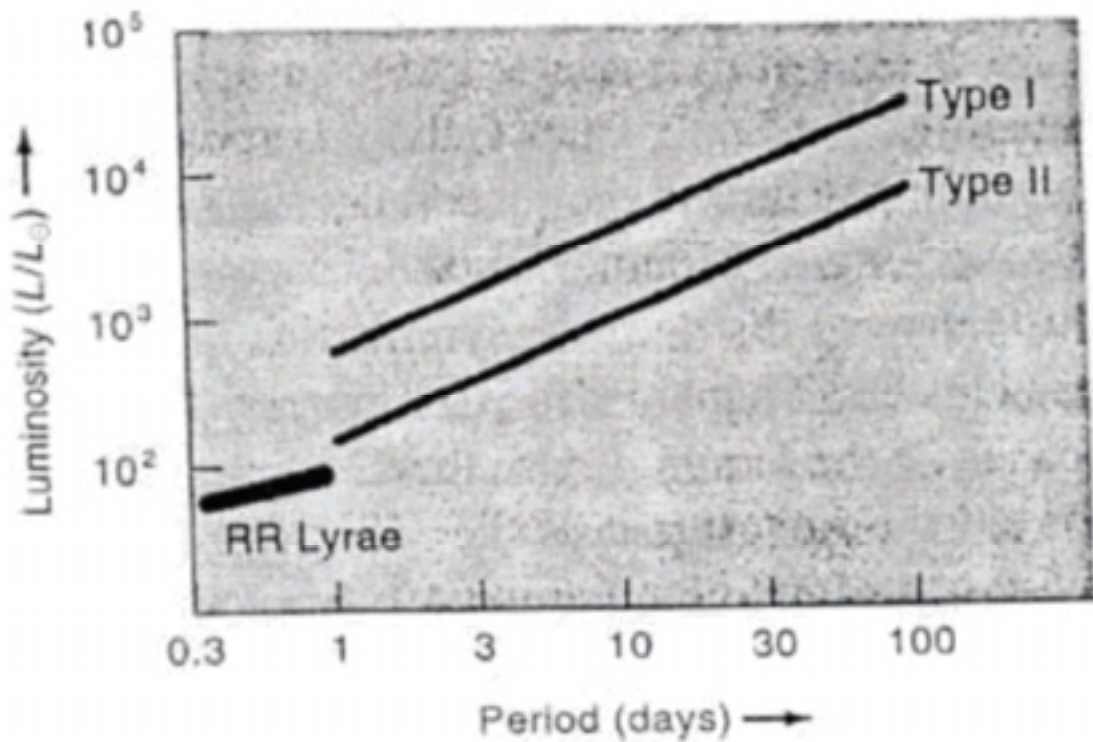

## “Breadth”

Breadth I. (Weinacht)

Consider Molecular Hydrogen ( $H_2$ ).

- a) (6 points) Draw the potential energy as a function of inter-atomic separation. Draw the potential energy for a Simple Harmonic Oscillator (SHO) on the same graph.
- b) (6 points) Which states of the real molecule will be most accurately described by the corresponding states of the SHO? How does the spacing between energy levels for a diatomic molecule compare to the energy level spacing of the SHO?
- c) (8 points) The difference between the vibrational ground state and the first excited state in  $H_2$  is about 0.54 eV. From this, determine the force between atoms for a displacement from equilibrium of 0.1 angstrom.

Potentially useful numbers are: Proton mass =  $1.67 * 10^{-27}$ kg  $\hbar = 1.05 * 10^{-34}$ Js Electron charge =  $1.60 * 10^{-19}$ C

Breadth II. (Mihaly)

We will investigate the possibility of metallic and insulating (semiconducting) states of solids in terms of two simple band structures: the tight binding and the nearly free electron models. Neglect the interaction between the electrons.

- a) (5 points) Consider a solid with one atom per unit cell. In the highest occupied energy level each atom has  $N$  degenerate orbitals and  $n$  electrons. The band structure is described by the tight binding approximation. In terms of  $N/n$ , what is the condition for this solid to be an insulator?
- b) (5 points) A simple one-dimensional chain of atoms has two electrons per atom. In the nearly free electron approximation this system is an insulator. Why? Illustrate your answer with a schematic drawing of the density of states.
- c) (5 points) In two or three dimensional square or cubic lattices the system with the same two electrons per atom will behave as a metal. Why? Illustrate your answer with a schematic drawing of the density of states.
- d) (5 points) Hydrogen has one electron on an energy level that can hold two, and according to the simple band model discussed in the first question, it should be a metal. Why is solid hydrogen an insulator?

Breadth III. (Jung)

(In giving your answers to this problem, make sure to indicate the specific flavor of the neutrinos whenever you refer to neutrinos, *e.g.*  $\nu_e, \nu_\mu, \nu_\tau$  and  $\nu_x$  for all three flavors. This problem extends to the next page.)

The 2002 Nobel Prize in physics was awarded to two neutrino physicists (Raymond Davis, Jr. and Masatoshi Koshiba) along with Riccardo Giacconi who pioneered X-ray astronomy. Davis was the first experimentalist who set out to observe neutrinos originating from the sun. He used 600 tons of dry cleaning fluid that contain  $^{37}\text{Cl}$  to detect the following reaction:

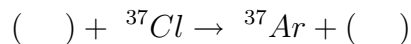

**a)** (2 points) Fill in the blanks above with appropriate particles for this experiment. While

the experiment resulted in a positive observation of the solar neutrinos, thus proving the basic principle of nucleosynthesis theory of star burning, the rate it observed was only about 1/3 of the predicted rate from the theory. This was the beginning of the so-called “Solar Neutrino Puzzle” that lasted for over 30 years. Some people questioned whether Davis’ experiment is really seeing the neutrinos coming from the sun.

**b)** (2 points) Explain why this experiment cannot definitively say that these observed neutrino events are due to the solar neutrinos by describing briefly the experimental technique and procedure.

Koshiba was instrumental in building the Kamiokande detector (a water Cherenkov detector) in Japan, and the experiment was able to detect the solar neutrinos in real time with the energy threshold of about  $7.5 \text{ MeV}$ . The experiment unambiguously showed that there are neutrinos coming from the sun.

**c)** (4 points) Draw two most relevant tree level Feynmann diagrams of solar neutrino interaction with the electrons in water.

**d)** (3 points) Explain how Kamiokande could tell unambiguously neutrinos are coming from the sun.

The total rate observed by the Kamiokande experiment (later by the Super-Kamiokande) was also smaller than the predicted rate by the Standard Solar Model (SSM) supporting the Davis’ experiment’s result, thus, making people look for solutions to solar neutrino puzzle other than simple experimental problems. The most popular solution to the solar neutrino puzzle is neutrino oscillation. Namely, if neutrinos have mass, solar neutrinos which are born deep inside the sun could transform to other flavor of neutrinos via neutrino oscillations either in the matter or in the vacuum.

**f)** (3 points) Show why neutrino flavour transformation can make the observed solar neutrino rate by Kamiokande less than the expectation without flavour transformation. Use your answer from (c) to make your argument.

While the reductions in the observed rates of the solar neutrinos by various experiments satisfy one aspect of the neutrino oscillation scenario, it is not sufficient enough to declare that we see evidence of neutrino oscillation in the solar neutrinos. The SNO experiment is designed to observe an unambiguous evidence of flavor transformation using heavy water as a target for solar neutrinos.

- g)** (3 points) Write down three different processes of solar neutrino interactions with heavy water involving deuterons and electrons.
- h)** (3 points) Explain how an unambiguous evidence of flavor transformation can be obtained by observing these three distinctive processes. (Assume there are only three light active neutrinos.)

Breadth IV. (Drees)

- a)** (6 pts.) Consider a nuclear beta decay in which a proton is converted into a neutron:

$$p \rightarrow n + e^+ + \nu$$

Draw a Feynman diagram for the decay and explain why the decay can only happen inside a nucleus.

- b)** (8 pts.) Show that  $^{22}\text{Na}$  can decay via  $\beta$ -decay. Calculate the energy change (Q-value) in the decay. Demonstrate that  $^{82}\text{Se}$  can not  $\beta$ -decay.

$$^{22}\text{Na}_{11} \rightarrow ^{22}\text{Ne}_{10} + e^+ + \nu$$

$$^{82}\text{Se}_{34} \rightarrow ^{82}\text{Br}_{35} + e^- + \bar{\nu}$$

- c)** (6 pts.) While  $^{82}\text{Se}$  can not  $\beta$ -decay to  $^{82}\text{Br}$  the double  $\beta$ -decay to  $^{82}\text{Kr}$  is possible. Write down the reaction and give the available decay energy. The decay has been observed with a lifetime  $4.4 \times 10^{20}$  years. Argue under what condition a neutrino less double  $\beta$ -decay would be possible and why it would require physics beyond the standard model.

Nuclear binding energies BE (for electrically neutral atoms with Z protons and N neutrons):

$$\text{BE}(Z=11, N=11) = - 174.1 \text{ MeV}$$

$$\text{BE}(Z=10, N=12) = - 177.8 \text{ MeV}$$

$$\text{BE}(Z=34, N=48) = - 712.8 \text{ MeV}$$

$$\text{BE}(Z=35, N=47) = - 711.9 \text{ MeV}$$

$$\text{BE}(Z=36, N=46) = - 714.3 \text{ MeV}$$

Masses:

$$m_p = 938.3 \text{ MeV}/c^2$$

$$m_n = 939.6 \text{ MeV}/c^2$$

$$m_e = 0.51 \text{ MeV}/c^2$$

Breadth V. (Evans)

In the last 15 years, there has been growing evidence that supermassive black holes exist in the central regions of all massive galaxies. This evidence has been provided primarily by monitoring the motions of stars near the centers of our galaxy and others.

- a) (6 points) A star approximately 2 pc from the center of our Galaxy is observed to be in a circular orbit and has a velocity of  $50 \text{ km s}^{-1}$ . If the mass internal to that star's orbit is primarily that of a supermassive nuclear black hole, calculate the approximate mass (in units of solar masses) of the black hole.
- b) (8 points) Active galaxies such as quasars and radio galaxies are believed to be powered by black holes. The standard condition for accretion of material onto a supermassive black hole is that the outward radiative force of the black hole and accretion disk must be less than the inward gravitational force; in the case where the forces are equal, the luminosity of the radiation is referred to as the Eddington Luminosity. Derive an expression for the mass of the black hole by making the assumption that the radiative and gravitational forces are exactly balanced. Express the mass in terms of the Eddington Luminosity and the Thompson scattering cross section,  $\sigma_T$ . Calculate the Eddington Luminosity (in units of solar luminosities) using the black hole mass derived from part A.
- c) (6 points) Imagine that the active galactic nuclei (AGN) luminosity,  $L_{\text{AGN}}$ , is proportional to the size of the broad line region (i.e., ionized gas whose motion is determined by its near proximity to the black hole) to the power  $\alpha$ , i.e.,  $L_{\text{AGN}} \propto R^\alpha$ , where  $\alpha$  is a known quantity. If  $L_{\text{AGN}}$  has been measured and a spectrum of the AGN and its host galaxy have been obtained, describe how one might use these data to test whether AGN follow the  $M_{\text{blackhole}} \propto \sigma_{\text{stars}}^4$  relation of nearby, normal galaxies, where  $M_{\text{blackhole}}$  is the mass of the supermassive black hole and  $\sigma_{\text{stars}}$  is the stellar velocity dispersion at the effective radius. (In other words, how would you determine  $M_{\text{blackhole}}$  and  $\sigma_{\text{stars}}$  given the data you have?)

**Useful constants:**

$$1 \text{ pc} = 3.09 \times 10^{16} \text{ m}$$

$$G = 6.67 \times 10^{-11} \text{ m}^3 \text{ kg}^{-1} \text{ s}^{-2}$$

$$1 \text{ Solar Mass} = M_\odot = 1.99 \times 10^{30} \text{ kg}$$

$$1 \text{ Solar Luminosity} = L_\odot = 3.90 \times 10^{26} \text{ W}$$

$$\sigma_T = 6.65 \times 10^{-29} \text{ m}^2$$

Breadth VI. (Lattimer)

The luminosity of a white dwarf can provide a good estimate of its age. Assume that the interior opacity of a white dwarf is extremely small, but that a thin radiative surface layer exists. In this layer, the opacity can be taken to be Kramer's-like, and the equation of state is that of a perfect gas.

- a)** (4 points) What is the dominant source of opacity in a white dwarf interior? Show that a vanishing opacity implies a negligible temperature gradient in the interior.
- b)** (6 points) Use hydrostatic equilibrium, the perfect gas law, and radiative transfer in the thin surface layer to find the qualitative relation between  $\rho$  and  $T$  in this layer:

$$\rho \propto \sqrt{\frac{M}{L}} T^{3.25} \quad (1)$$

where  $L$  and  $M$  are the star's luminosity and mass, respectively. You can solve this by dimensional analysis, or by constructing a differential equation involving the density and temperature by eliminating the pressure.

- c)** (5 points) Assume that the white dwarf interior is degenerate and non-relativistic. Then show that the density  $\rho_*$  and temperature  $T_*$  at which the degenerate electron pressure equals the non-degenerate gas pressure are related by

$$\rho_* \propto T_*^{3/2}. \quad (2)$$

- d)** (5 points) Assume the quantitative relations for Eqs 1 and 2 are

$$\rho = 4 \cdot 10^{-22} \sqrt{\frac{M}{M_\odot} \frac{L_\odot}{L}} T^{3.25} (\text{cgs}), \quad (3)$$

$$\rho_* = 10^{-8} T_*^{3/2} (\text{cgs}). \quad (4)$$

Show that by matching these two relations that the mass-luminosity-temperature relation for a white dwarf is approximately

$$\frac{L}{L_\odot} = 1.6 \cdot 10^{-27} \frac{M}{M_\odot} T_*^{3.5} (\text{cgs}). \quad (5)$$

Compare this to the blackbody emission from a white dwarf with a surface temperature  $T_{eff}$  (the Stefan-Boltzmann constant is  $5.67 \cdot 10^{-5}$  in cgs units). What does this imply about  $T_{eff}$ ?